

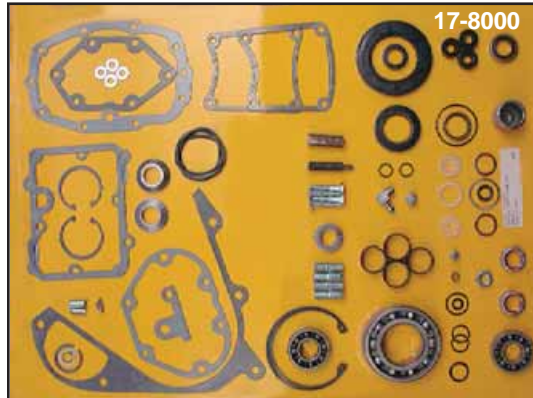

Transmission

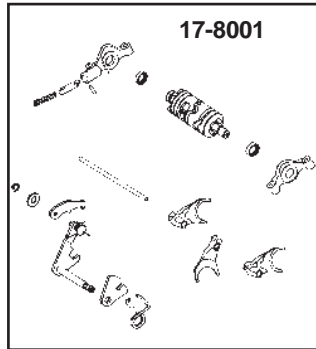
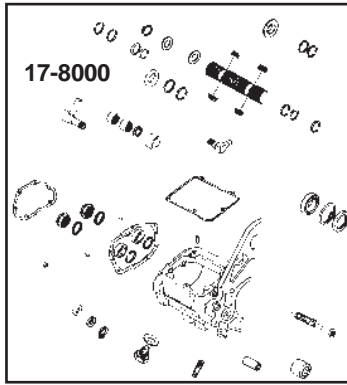

GB™ Big Twin 5-Speed Builder's Kits include all parts noted by each illustration.

VT No.	Type
17-8000	Internal Small Parts Kit
17-8001	Shift Shaft Drum Assembly, 1979-97

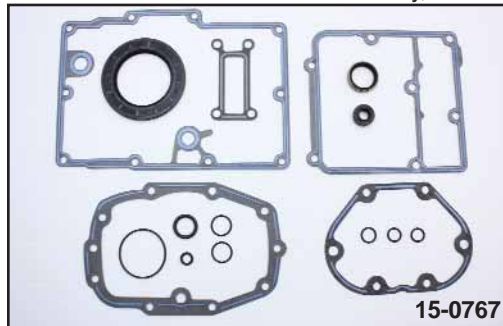

1999-up Transmission Gaskets for TC-88. James brand unless noted.

VT No.	OEM Type
15-1243	Kit 1999-up Trans Gasket Kit
15-0767	Kit FXD Trans Kit (GB)

5-Speed Transmission Gasket Kit

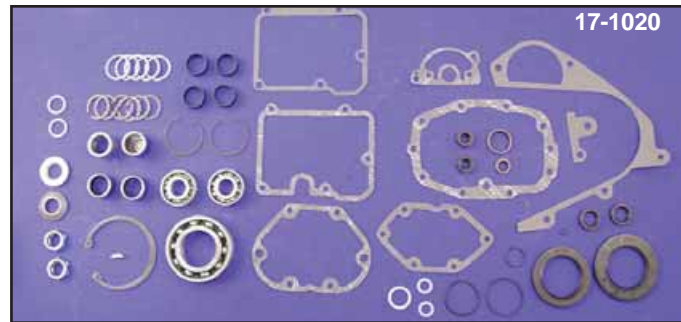

5-Speed Jims Hardware & Rebuild Kit includes bushings, locks, keys & snap rings for completing as 5 spd transmission rebuild. James gasket set included.

VT No.	Year
17-1019	1980-E84
17-1020	L1984-90
17-1021	1991-98
17-1035	1999-up



Transmission Gasket Sets. Complete gasket and oil seal kit listed below for individual application.

James	GB No.	OEM	Fits
15-0841	15-0619	33031-82	1980-84 Big Twin 5-Speed
15-0841	15-0641	33031-85	1985-99 Big Twin 5-Speed
15-0842	15-0762	33031-91	1991-99 Dyna FXDB-S
15-1243	15-0767	—	1999-up FXD
15-0843	15-0763	33031-93	1993-99 FLHS-FLHTC
15-1211	15-0764	33031-99	1999-up TC-88



James Transmission 5-Speed Seal Kits.

VT No.	Year
15-1166	1984-93
15-1167	1994-up



Big Twin Transmission Sprocket Oil Seal Kit.

VT No.	Year	Speed
15-1166	1984-94	5
15-1167	1995-06	5
15-0767*	1999-05	5 (FXD)
15-1276	2006-up	Dyna
	2007-up	All Big Twins

*Note: GB Brand.



5-Speed Big Twin Main Drive Gear Oil Seal and Spacer Kit features three lip seal and coated sprocket spacer. The coating provides superior surface lubricity and increased corrosion resistance. Fits 1994-up as a replacement or on ratio change on earlier models with late pulley.

VT No. 17-0752