

# Big Twin Pinion Hardware

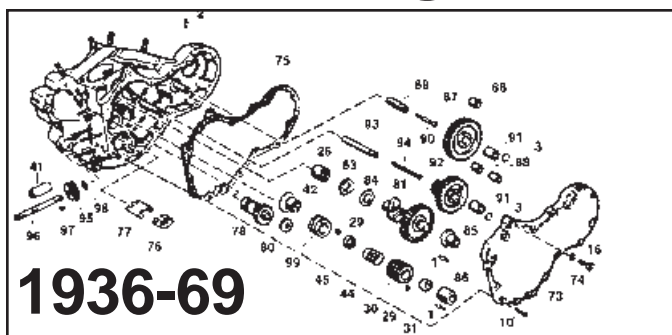

## 1936-69

VT No.	OEM	#	Year/Item
12-1175	271	1	1936-up Bushing Pin
12-1166	377	2	1941-69 Pin
12-0915	25810-15	3	1937-57 Idler & Circuit Breaker Shaft Retaining Ring
8149-12	Chrome	10	1936-69 Screw, set
8150-12	Cadmium	10	1936-69 Screw, set
10-0714	25597-36	26	1936-57 Cam Bushing
10-2527	As Above	26	.005 O.S.
12-0316	9058	26	1958-up Needle Bearing
12-0202	23985-54	29	1954-up Key
12-1379	24010-54	30	1954-77 Pinion Gear
12-1399	24010-39	30	1939-53 Pinion Gear
12-0507	24023-54	31	1954-89 Nut
10-0703	24641-36	41	1936-up Bushing
12-1525	24692-40	42	1940-53 Seal Ring
13-0105	24699-37	44	1937-69 Spring
12-1521	24703-54	45	1954-69 Spacer
12-1520	24703-40	45	1940-53 Spacer
10-0065	25216-36	73	1936-47 Gear Cover
10-0066	25216-48	73	1948-53 Gear Cover
10-0068	25216-58	73	1954-62 Gear Cover
10-0077	25216-65	73	1963-65 Gear Cover
8771-2	25218-63	74	1963-65 Chrome Bolt w/16
8772-2	25218-63	74	1963-65 Cadmium Bolt w/16
15-0122	25225-36C	75	1941-69 Gasket
12-1517	25275-36	76	1936-69 Breather Screen
12-1518	25279-36	77	1936-69 Separator
12-9967	25300-36	78	1936-47 Breather Valve STD, S&S
12-9968	—	—	As Above .030 O.S.
12-9907*	25300-36	78	1941-77 Breather Valve STD, S&S
12-9956*	—	—	As Above .030 O.S.
12-9909	S&S	80	Washers for above, set
12-1536	25300-36	78	1941-77 Breather Valve STD
12-9978	Sifton	80	Washers for Above
12-1509	25313-50	80	1950-78 .115, 4 pk., 1 of ea.
	25314-50		.120 Breather
	25315-50		.125 Washer
	25316-52		.110 Set
17-0908	25550-57	83	1958-up Lock Washer
10-1254	25550-84	84	1984-up .045 Thick
12-1508	—	84	1936-up Cam Gear
			Washer Set .050-.095
12-1440	25550-36	84	.050 Cam Gear Washer
12-1441	25551-36	84	.055 Cam Gear Washer
12-1425	25552-36	84	.060 Cam Gear Washer
12-1426	25553-36	84	.065 Cam Gear Washer
12-1427	25554-36	84	.070 Cam Gear Washer
12-1428	25555-36	84	.075 Cam Gear Washer
12-1429	—	84	.080 Cam Gear Washer
12-1430	—	84	.085 Cam Gear Washer
12-1431	—	84	.090 Cam Gear Washer
12-1432	—	84	.095 Cam Gear Washer
12-1433	—	84	.100 Cam Gear Washer
10-0704	25581-36	85	1941-69 Bushing, STD
10-2524	As Above	85	.005 O/S
10-0706	25582-36	86	1936-53 Cam Cover Bush STD
10-2526	As Above	86	1936-53 .005 O/S
10-0707	25582-54	86	1954-72 Bushing, STD
10-2529	As Above	86	.005 O/S
12-1388	25775-36	87	1936-69 Idler Gear, S&S
12-1397	25775-36	87	1936-69 Idler Gear
12-1393	As Above	87	with Holes
10-0716	25785-30A	88	1936-69 Idler Bushing
10-0801	25791-36	89	1936-69 Idler Stud
12-0198	25794-36	90	1936-69 Screw
10-0807	25800-36	91	1936-69 Spacer
10-0808	25800-36B	91	1936-69 Spacer, .750 O.D.
12-1396	25850-36A	92	1936-69 C.B. Drive Gear
12-1479	25850-36	92	1936-47 C.B. Drive Gear
12-1389	25850-36A	92	1936-69 C.B. Drive Gear, S&S
10-0802	25856-36	93	1936-69 C.B. Drive Gear Stud
12-0199	25859-36	94	1936-58 C.B. Stud Screw, RH
12-0196	1430	94	1959-69 Screw, L.H.
12-1409	26345-39	95	1939-72 Drive Gear, 25T, USA
12-1449	26345-39	95	1939-72 Drive Gear, 25T
12-0803	26346-36	96	1936-67 Gear Shaft
12-0804	26346-68	96	1968-69 Gear Shaft
12-0205	26348-15	97	1936-up Oil Pump Key
12-0916	26348-36	98	1936-69 Ret. Ring
12-1395	26349-39	99	1939-53 Drive Gear
12-1496	26349-39	99	1939-53 Drive Gear
12-1450	26349-54	99	1954-72 Drive Gear

Note: Must be used with 1954-77 Pinion & Cam Gears.

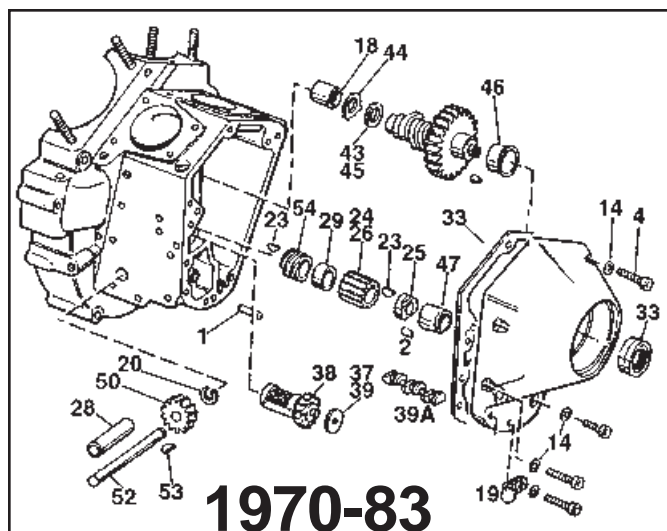

## 1970-83

### 1970-83 Big Twin Pinion Hardware

VT No.	OEM	#	Year/Item
12-1184	275	1	1970-up Bushing Pin
12-1153	358	2	1970-up Dowel Pin
8761-7	Kit	4	1970-92 Chrome Allen Screw Set
9305-7	Kit	4	1970-92 Stock Chrome Screws
9306-7	Kit	4	1970-92 Stock Cadmium Screws
9633-50	6099	14	1970-up Washer, Chrome
12-0316	9058	18	1970-up Needle Bearing
37-8971	10046	19	1981-up Wire Clamp
12-0901	11002	20	1970-up Oil Pump Retainer Ring
12-0202	23985-54	23	1970-up Key, Gear Shaft
12-1379	24010-54	24	1970-77 Pinion Gear
12-1379	24010-54	24	1970-77 Pinion Gear
Note:	24040-78	24	L1977-up Pinion Gear
<b>See Chart for Pinion Gear Listing</b>			
12-0507	24023-54	25	1970-89 Pinion Gear Nut
12-0613	24023-54	25	1970-89 Pinion Gear Nut, Jims
10-0703	24641-36	28	1970-up Oil Pump Shaft Bush
12-1539	24703-54B	29	1970-89 Pinion Gear Spacer
12-9922	24704-90	29	1990-up Pinion Gear Spacer
15-0871	25225-70B	33	1970-92 Gasket and Seal Kit
12-9907*	25300-36	38	1941-77 Breather Valve, S&S
12-9956*	—	38	1941-77 Breather Valve, S&S, .030 O.S.
12-9906	25313-77	38	1978-85 Breather Valve, S&S
12-9957	—	38	1978-85 Breather Valve, S&S, .030 O.S.
12-9909	S&S	37	Washers for Above (Set)
12-1536	25300-36	38	1941-77 Breather Gear, Sifton Steel
12-9919	25313-73	38	1973-76 Breather Gear
12-1537	25313-77	38	1978-99 Breather Gear, Sifton Steel
12-9978	—	37	Washers for Above, Sifton
12-1534	25310-91A	38	1970-E77 Breather Valve (Plastic)
12-1531	25310-82	38	1982-90 1992-up Breather Valve (Plastic)
12-1509	25313-50	39	1950-78 .110-.125 4 Piece Set
12-1510	—	39	1979-82 .110-.145 Set, 8 pk.
12-1530	Nylon	39	1982-up .130-.165 Set, 8 pk.
12-1508	25550-36	43	1970-up Cam Gear
			Washer Set .050-.095 (10 pc.)
10-1254	25550-84	43	1984-up .045 Thick, 5 pk.
12-1440	—	43	.050 Cam Gear Washer
12-1441	—	43	.055 Cam Gear Washer
12-1425	—	43	.060 Cam Gear Washer
12-1426	—	43	.065 Cam Gear Washer
12-1427	—	43	.070 Cam Gear Washer
12-1428	—	43	.075 Cam Gear Washer
12-1429	—	43	.080 Cam Gear Washer
12-1430	—	43	.085 Cam Gear Washer
12-1431	—	43	.090 Cam Gear Washer
12-1432	—	43	.095 Cam Gear Washer
12-1433	—	43	.100 Cam Gear Washer
17-0908	25550-57	44	1958-up Lock Washer, 5 pk.
10-0705	25581-70	46	1970-up Bushing
10-2525	25581-70	46	1970-up Bushing, .005 Oversize
10-0707	25582-54	47	1954-72 Bushing, STD, ea.
10-0708	25582-73	47	1973-92 Bushing STD
10-2529	As Above	47	1973-92 Bushing .005 O/S
12-1409	26345-39	50	1939-72 Drive Gear, 25T
12-1407	26345-73	50	1973-up Drive Gear, 24T
12-0805	26346-70	52	1970-up Gear Shaft
12-0205	26348-15	53	1936-up Oil Pump Key, 10 pk.
12-1450	26349-54	54	1954-72 Drive Gear
12-1408	26349-73	54	1973-83 Drive Gear

\*Note: Must be used