

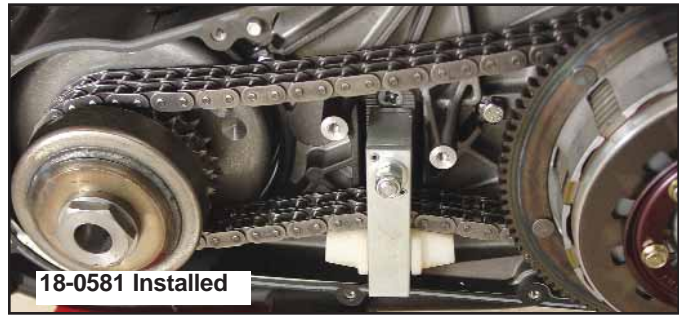

Chain Tensioners Primary Chain

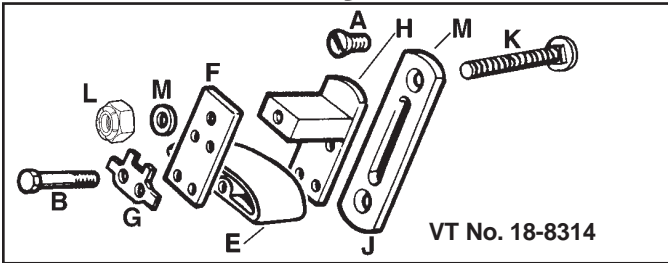

York Chain Adjuster Kits feature automatic self adjusting by use of spring loaded shoe.

VT No. Year
18-0580 1965-00
18-0581 2001-05

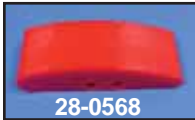

28-0568



28-0225



18-8314



18-0581



18-0580

Chain Tensioner Parts fits Big Twin models.

VT No.	#	OEM	Type	Years
18-8314		All	Complete Kit	1985-2000
18-8320		All	Complete Kit	2001-up
18-3217		B-C-F-G	Hardware Kit	
37-9030	A	1783	Screw, 10 pack	
37-8801	B	3862B	Bolt, 5 pack	
18-3682*	C	4401W	Hex Bolt, each	
28-0225	E	39976-65B	Nylon Pad	1965-2000
28-0568		Red	Nylon Pad	1965-2000
28-0234	E	39976-01	Nylon Pad	2001-up
17-0915	G	39996-65	Lock, 10 pack	
18-3218	H	39990-65	Shoe Mount Bracket	1965-2000
18-8321	H	39990-01	Shoe Mount Bracket	2001-up
18-3219	F	39993-65	Plate	
18-3622	I	39992-65A	Nut and	
	J	39998-65	Anchor Plate	
18-3634	J	—	Anchor Plate w/carriage bolt (K)	
37-8802	K	5444	Carriage Bolt, 5 pack	
18-3223	I	39992-65A	Nut Only	

*Note: Early style Hex Bolt, screws into 18-3223 Nut.



York Big Twin Hydraulic Primary Chain Tensionator™ features a hydraulic valve which controls the motion of the submerged piston which constantly keeps the chain in tension for 1965-up Big Twins.

VT No. 18-0120



Automatic Spring Loaded Chain Tensioner.

VT No. Year
18-0700 1985-05 BT
18-0702 2006-up FXD, 2007-up FXST

Installation Instructions

- 1) Drain oil.
- 2) Remove the primary cover, the original adjuster shoe with the bracket and the carriage screw.
- 3) Install the longer carriage screw from the kit into the serrated adjuster pad.
- 4) Install the inner guide onto the carriage screw. Install the shoe with the springs onto the inner guide and place the outer guide onto the inner guide pins as shown.
- 5) Position the shoe, springs and guide assembly at the lowest point of possible adjustment on the pad. Install the original carriage screw lock nut and tighten it.
- 6) The amount of spring exposed from the bottom of the shoe will depend on chain wear. It should be 5/8 inch or less.
- 7) If more than 5/8 inch exists, raise the bottom of the spring by loosening the nut and raising the assembly for kit 18-0580 or by using shims provided for kit 18-0581. Make this adjustment until 5/8 inch of spring is exposed.
- 8) Replace the primary cover with a new gasket and fill it with oil to the proper level.

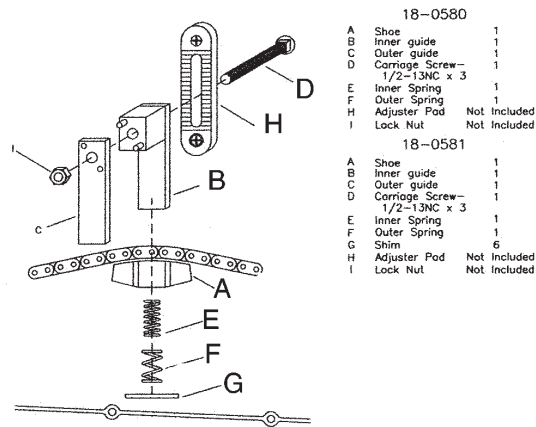

M-6 Self Adjusting Chain Tensioner fits Big Twin 4 and 5 speed models with wet clutch. Replaces factory type detent adjuster shoe assembly. Tensioner kit includes all hardware and instructions for complete conversion.

VT No. Year
18-3662 1965-2000
18-3681 Nylon Pad

